



Bundesnetzagentur

Kapazitätssicherung in Rahmenverträgen - de lege lata und de lege ferenda

Dr. Johannes Arnade, Referent
Workshop zum Eisenbahnrecht
Berlin, 30.06.2016



www.bundesnetzagentur.de



I. Rechtsquellen

II. Vergleich altes vs. neues Recht

III. Fazit und Ausblick

I. Rechtsquellen



Richtlinie 2001/14/EG

Allgemeines Eisenbahngesetz

Eisenbahninfrastruktur-Benutzungsverordnung

Richtlinie 2012/34/EU („Recast“)

Durchführungsverordnung (EU) 2016/545

Eisenbahnregulierungsgesetz

II. Vergleich altes vs. neues Recht

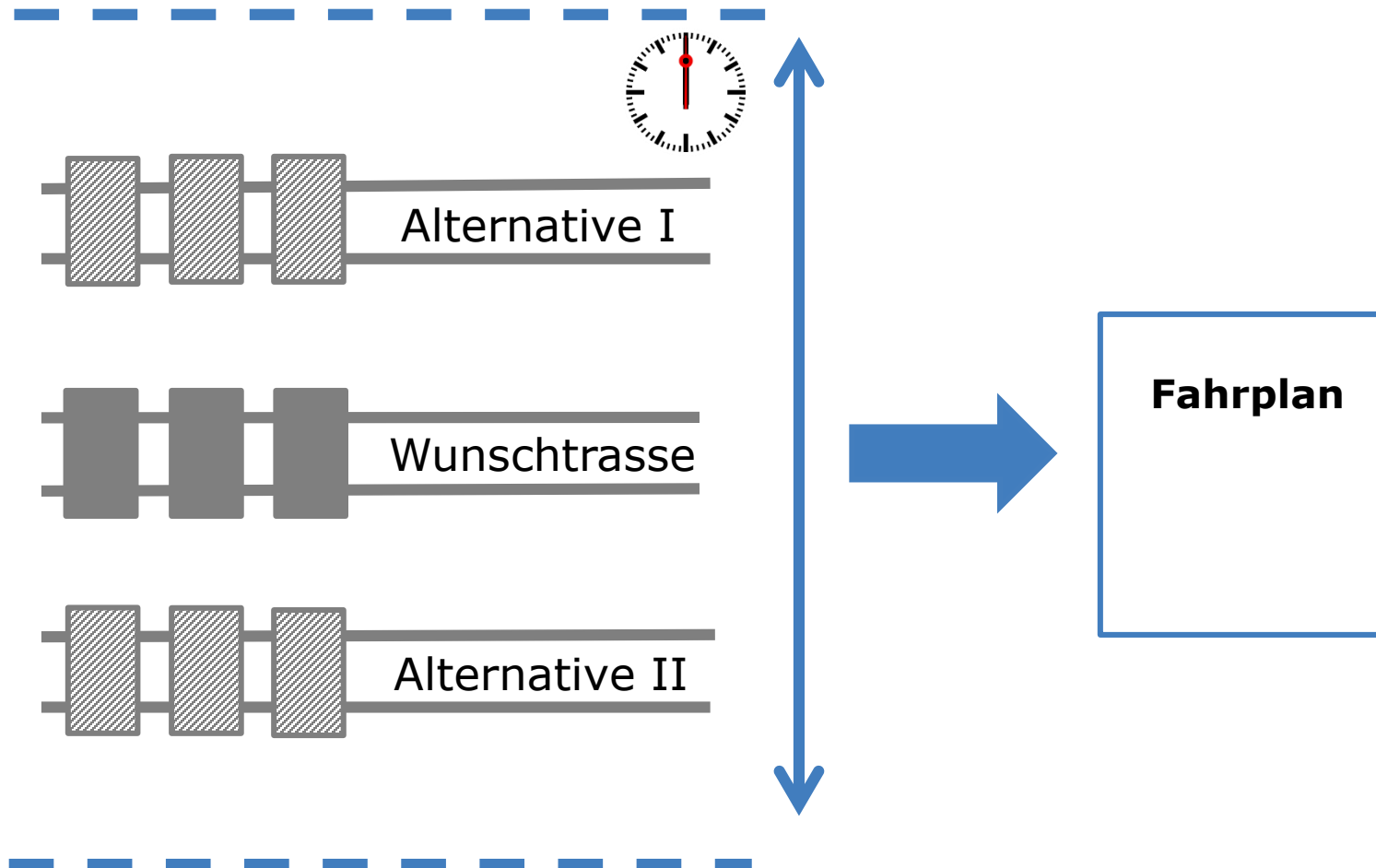

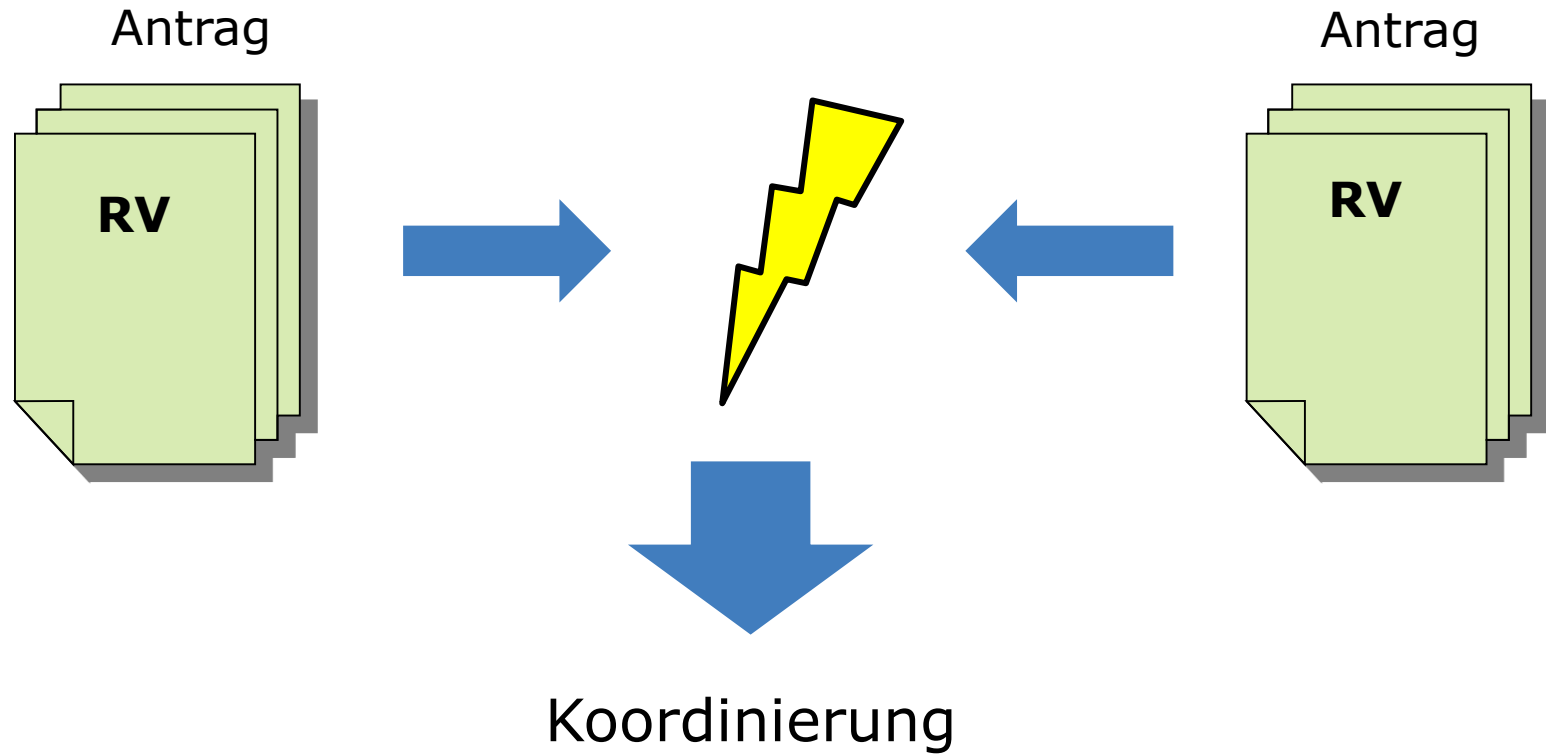

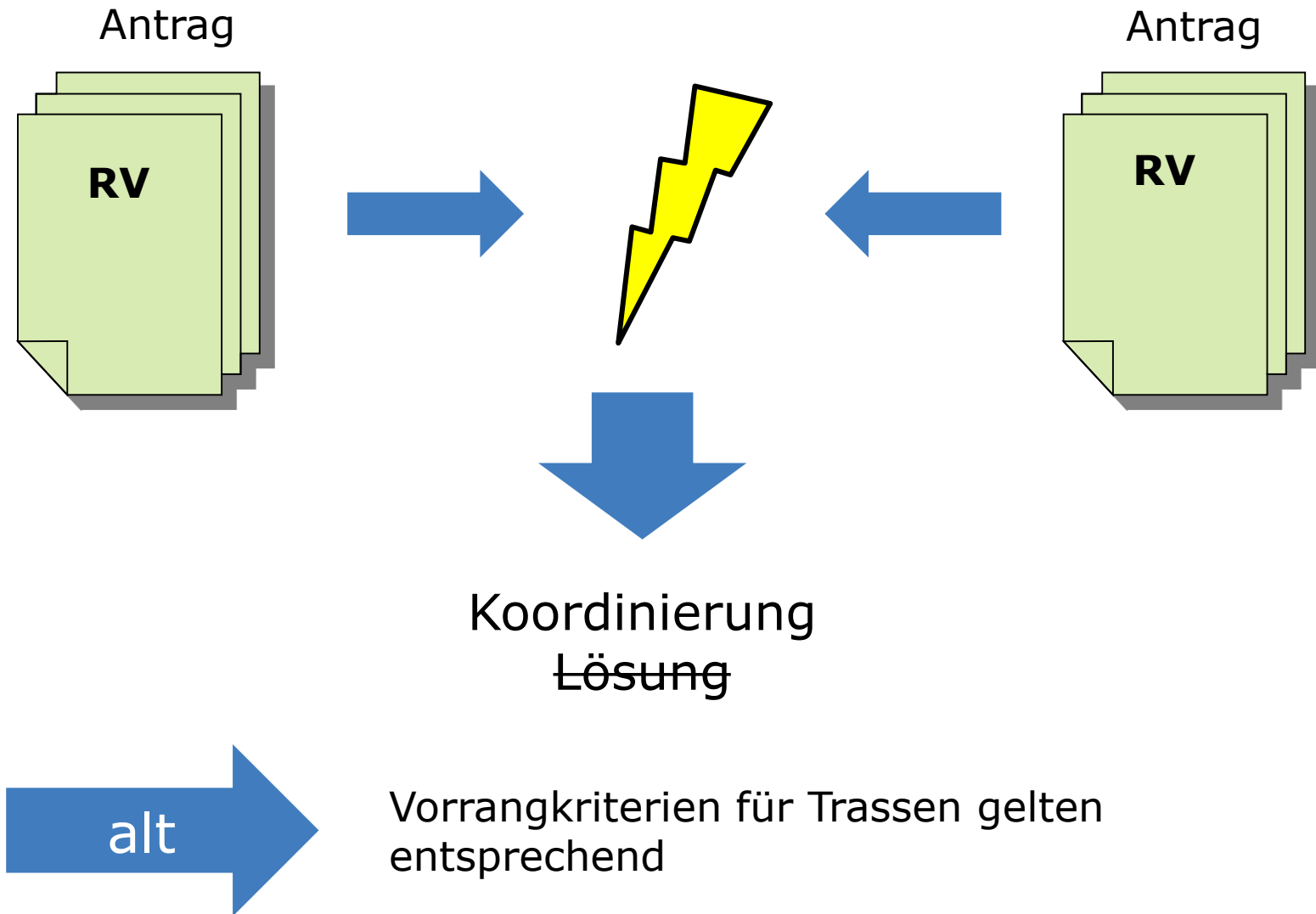

Antrag 2018

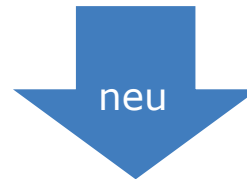
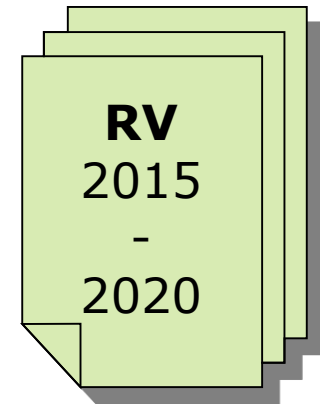
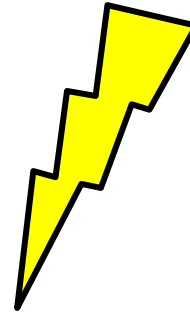
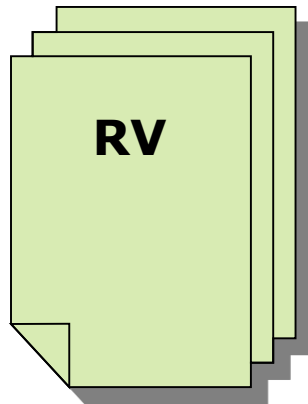

Koordinierung

Antrag 2018

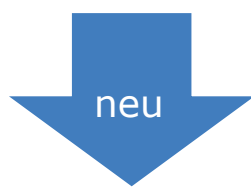
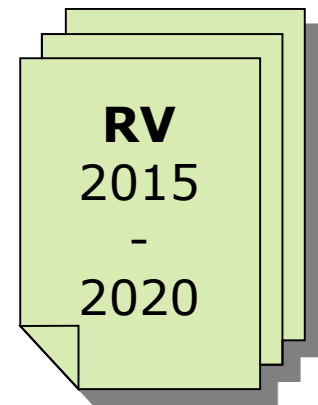
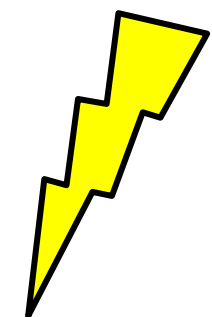
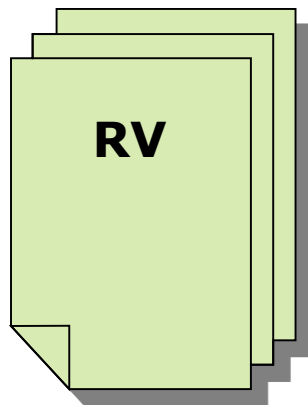

Koordinierung
Lösung



Bessere Nutzung der
Infrastruktur?



BdS



Tragfähigkeit des Geschäftsmodells /
Wirtschaftlichkeit eines öffentlichen
Dienstleistungsauftrags nicht
gefährdet



Vorrangkriterien für die
Trassenvergabe



Umfang der zugewiesenen oder
beantragten Kapazität



...

Anmeldung 2018

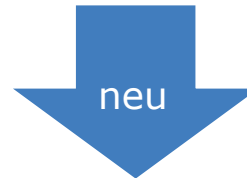
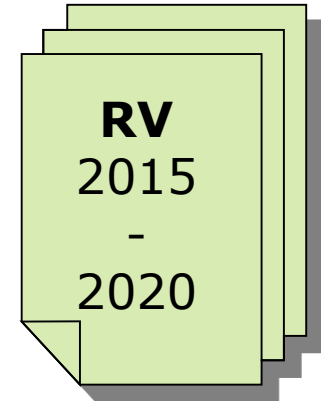
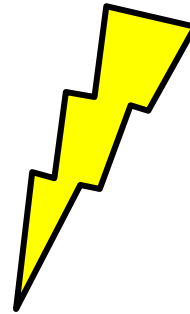
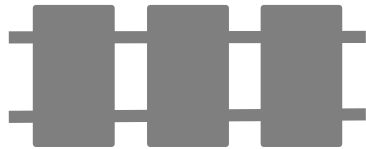

Koordinierung

Anmeldung 2018

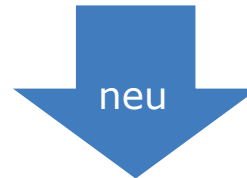
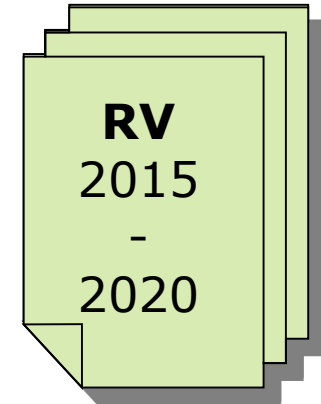
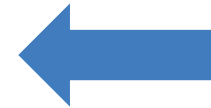
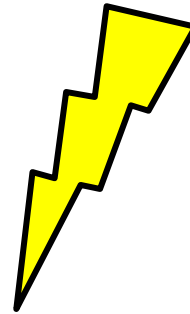
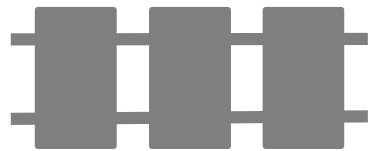

Koordinierung
Lösung

Bessere Nutzung der
Infrastruktur?

BdS



Anmeldung ohne RV

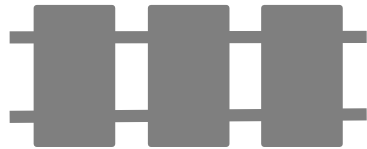

Anmeldung mit RV

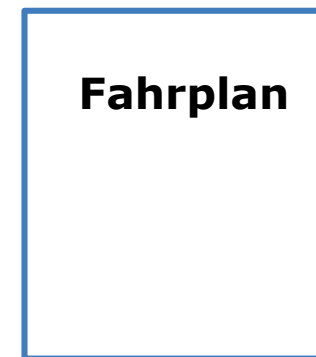
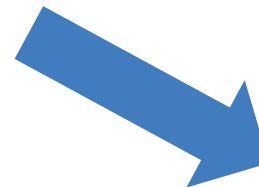
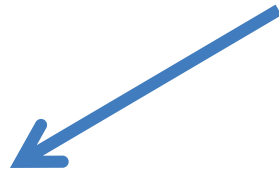
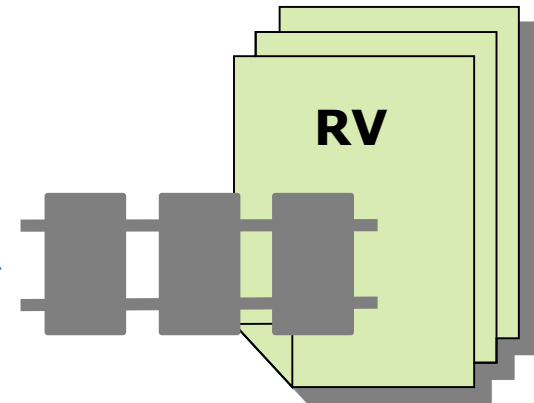

~~Bessere Nutzung der
Infrastruktur?~~

Optimale
Nutzung

Bedürfnisse
Fahrgäste,
SGV,
Investoren

Effizienter
Betrieb

Vorrangkriterien
für Trassen

Verwaltung
des Netzes

...

neu

BdS



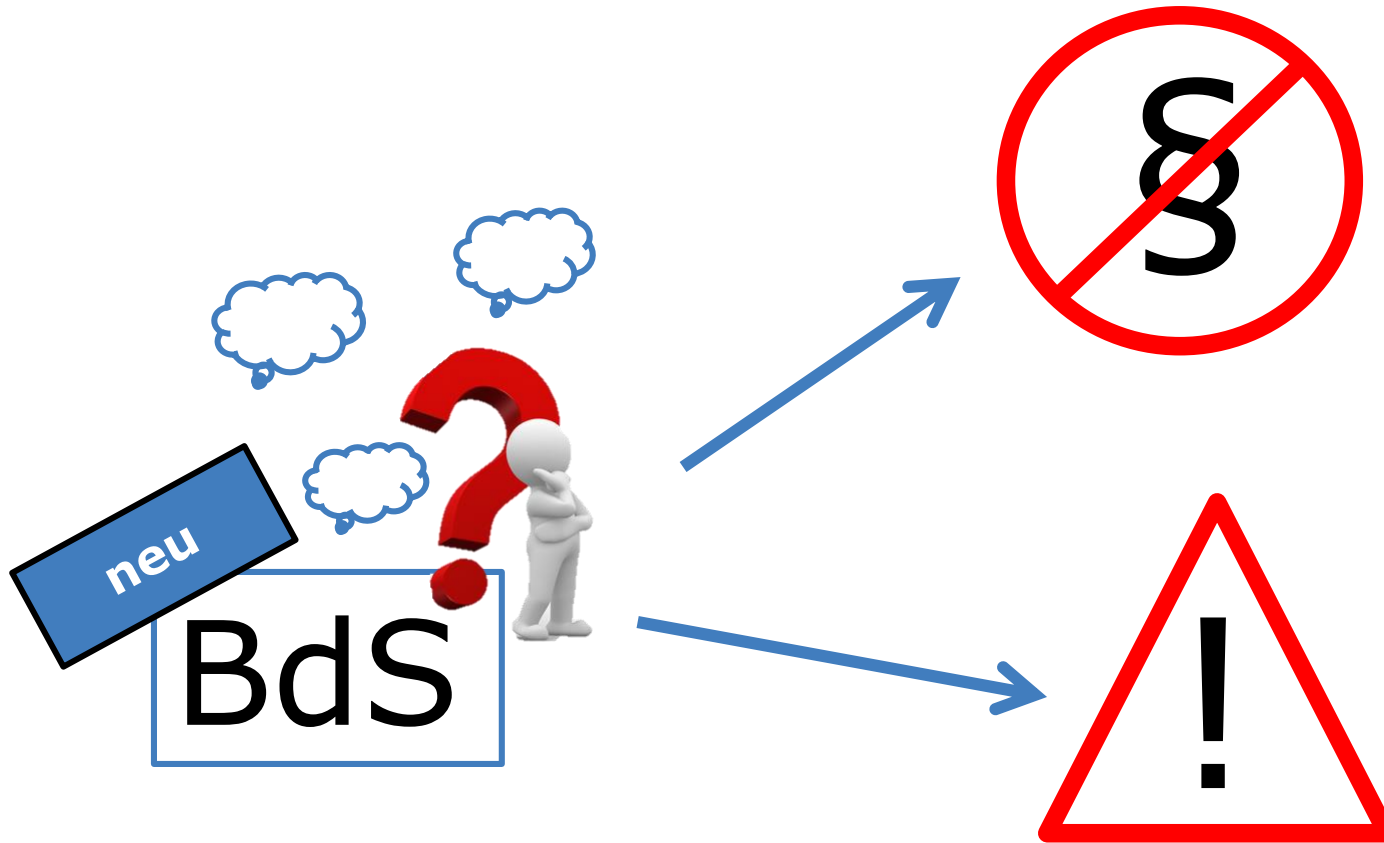

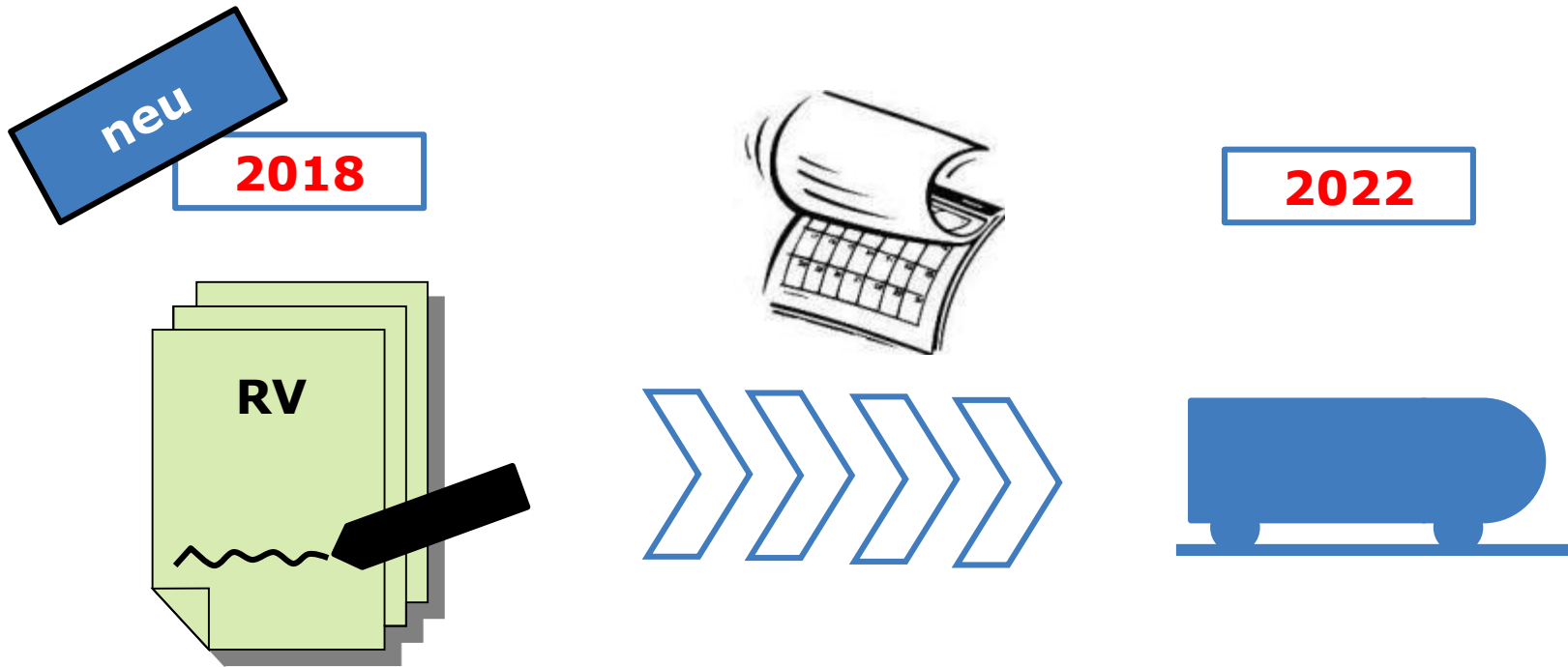

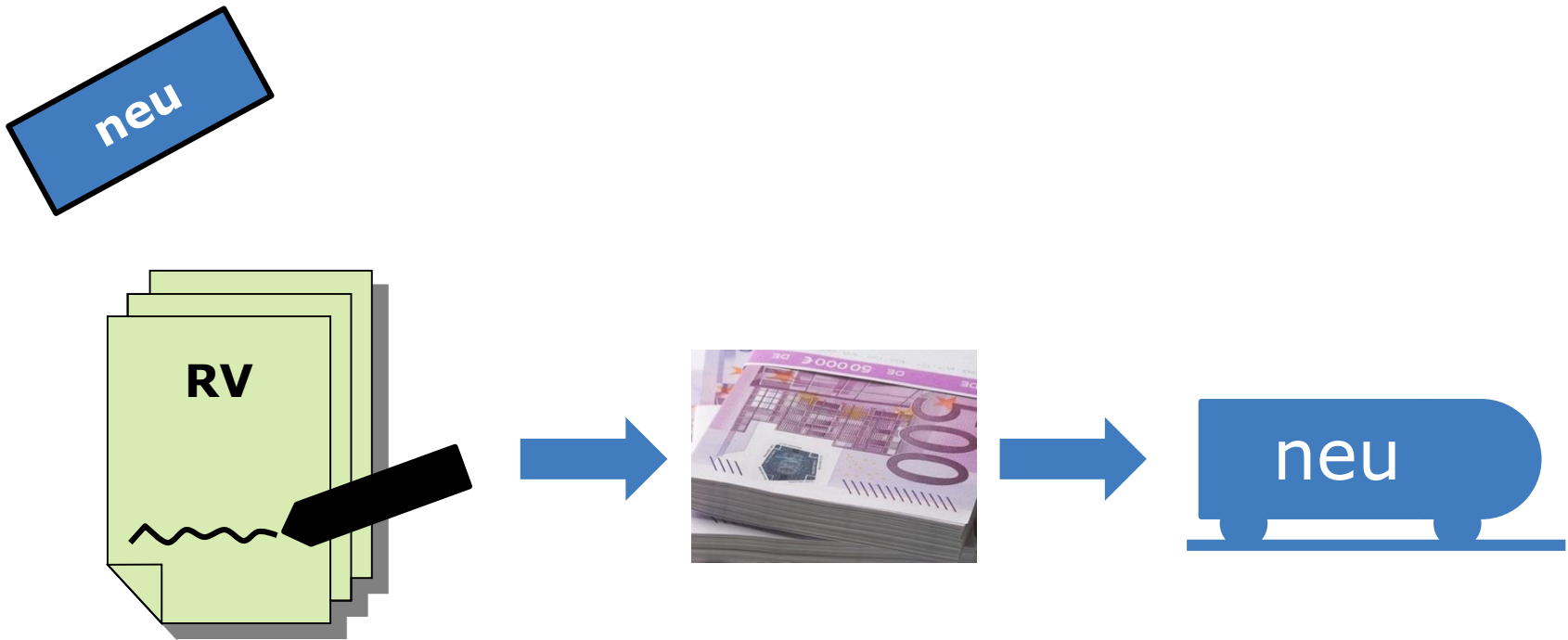

neu



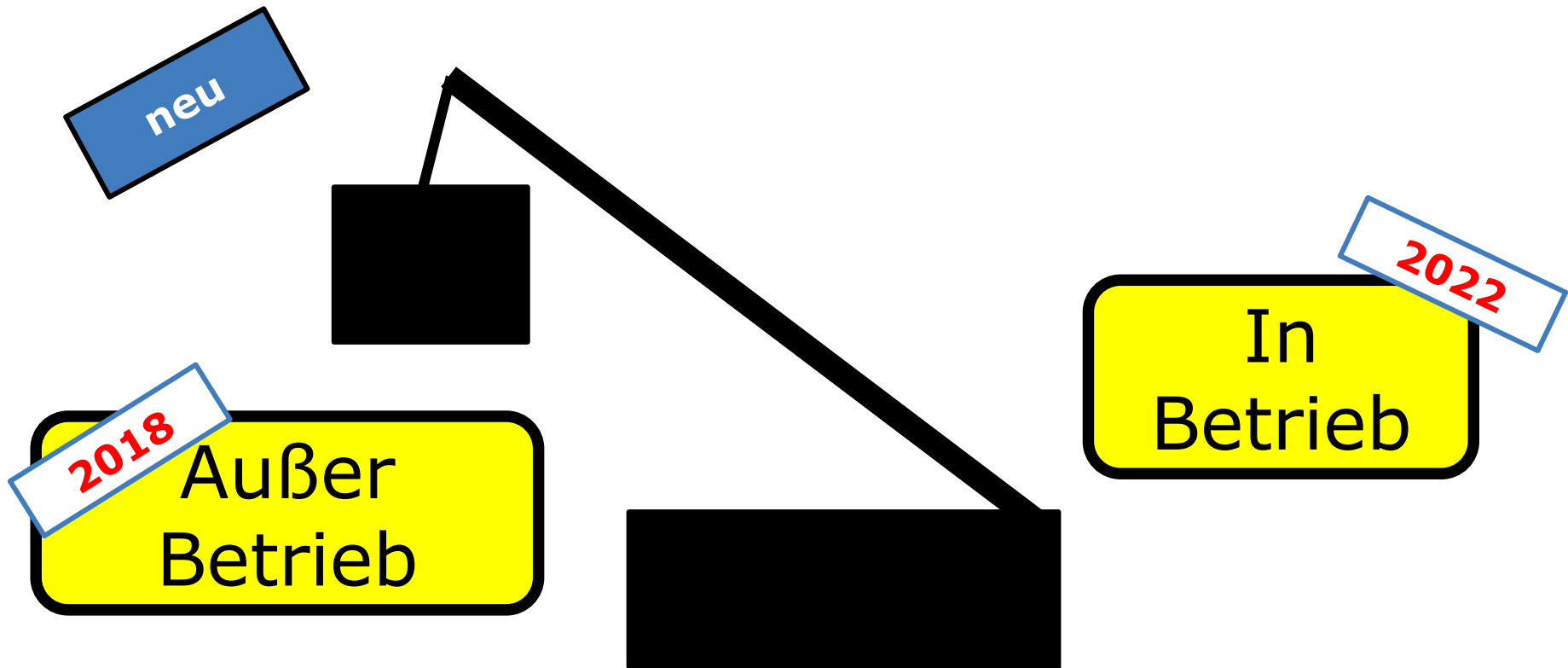



neu

Erforderlich wegen Bestimmungen in einem bestehenden öffentlichen Dienstleistungsauftrag

bundes | arbeits | gemeinschaft
BAGSPNV
schienen | personen | nah | verkehr

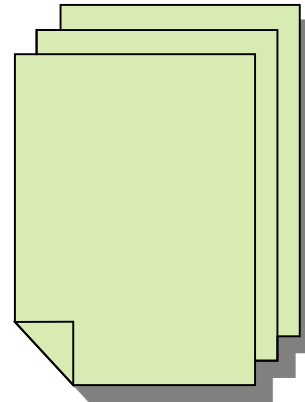

3. Arten von Rahmenverträgen (1)

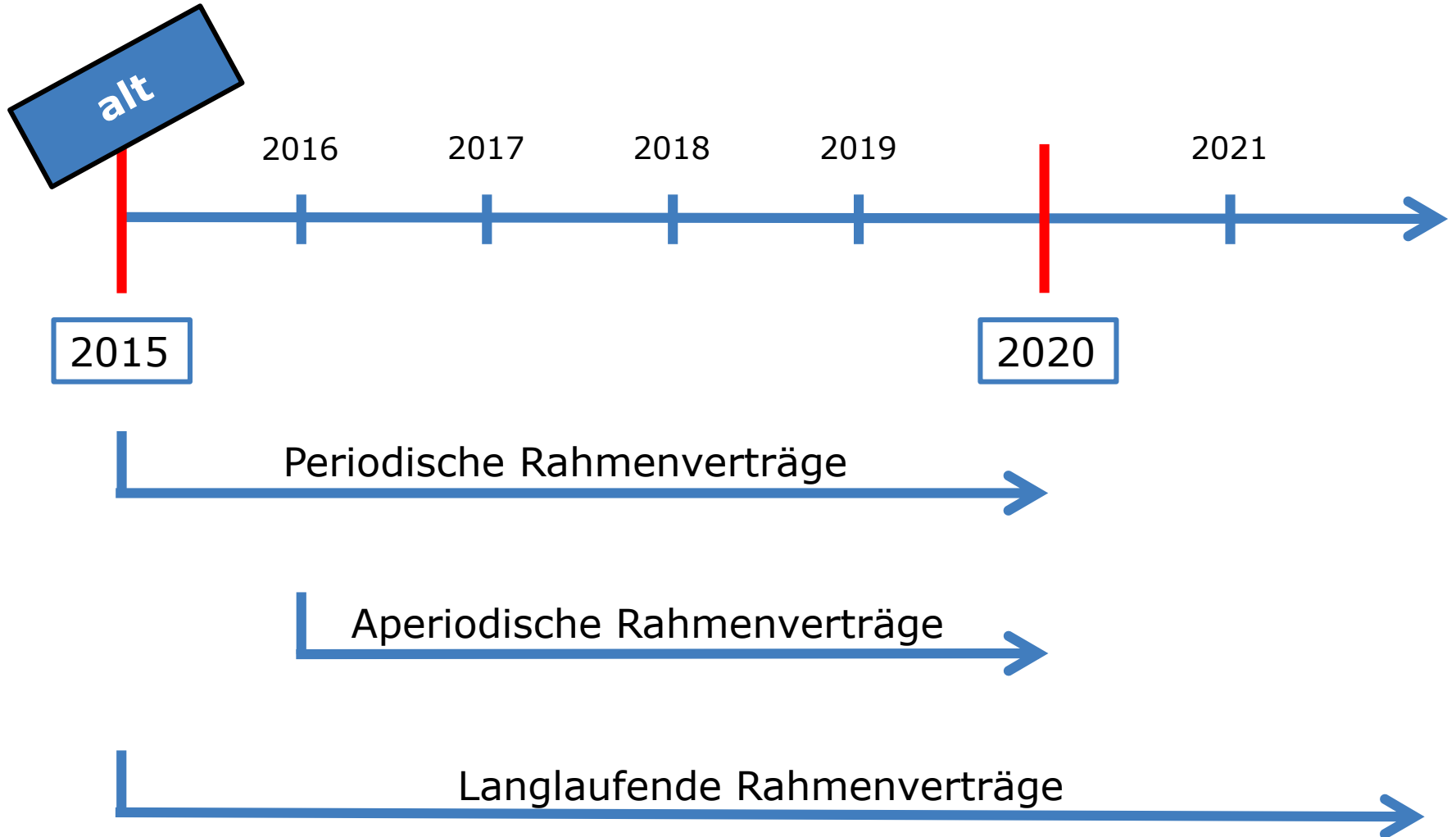

3. Arten von Rahmenverträgen (2)

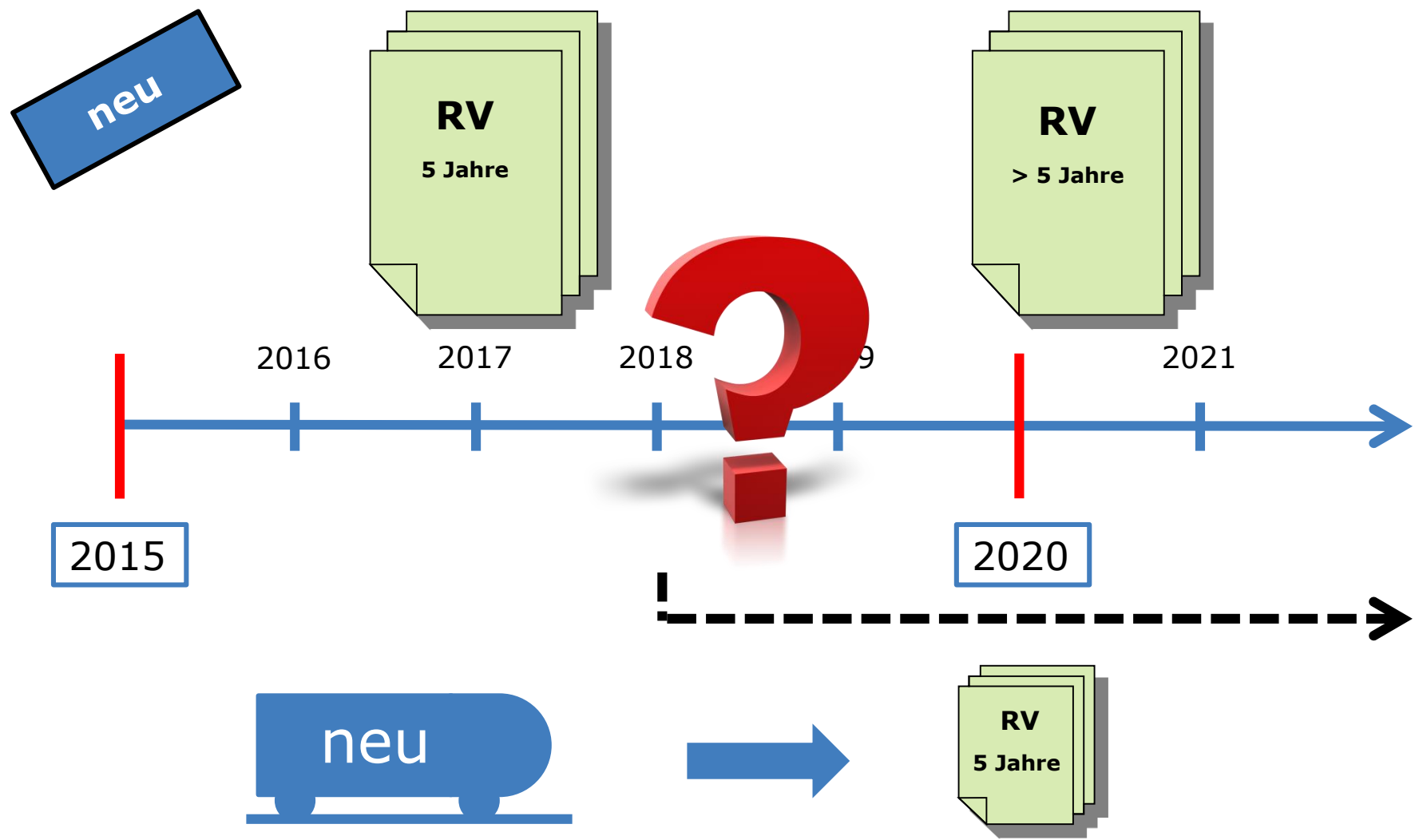

alt

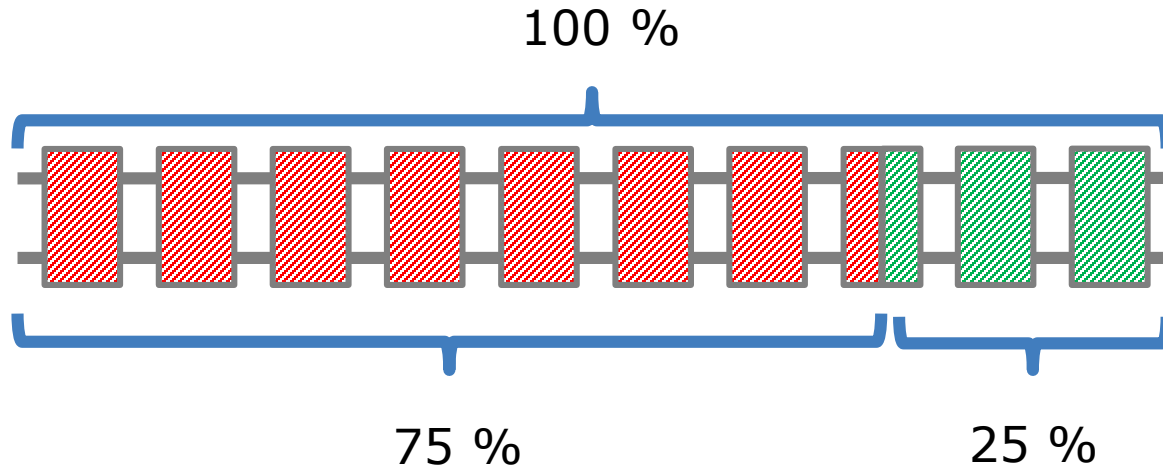

§ 13 Abs. 2 EIBV: Soll-Vorschrift

neu

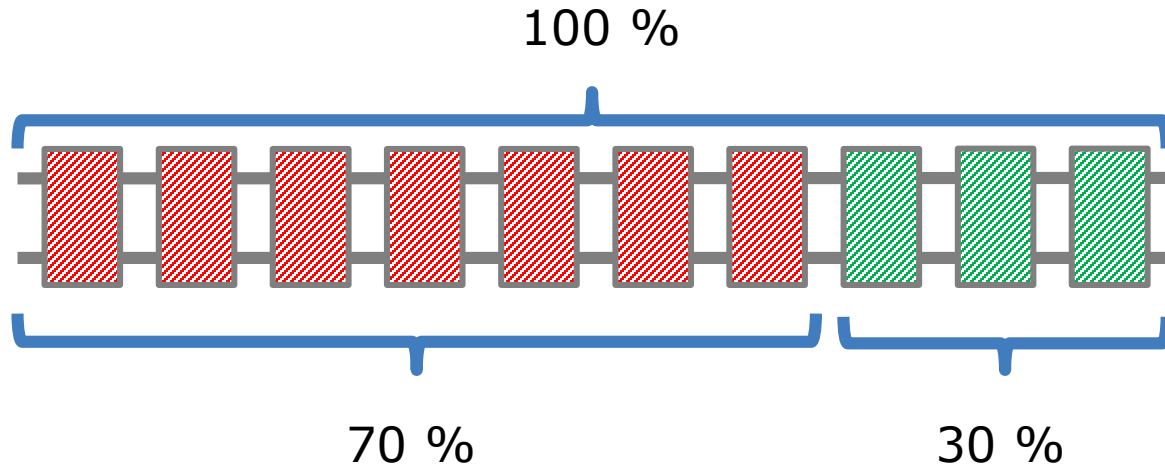

< 70 %: ~~Bessere Nutzung der Infrastruktur?~~

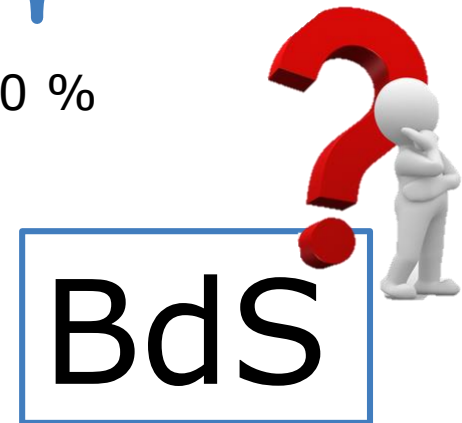

Anmeldung ohne RV

Anmeldung mit RV

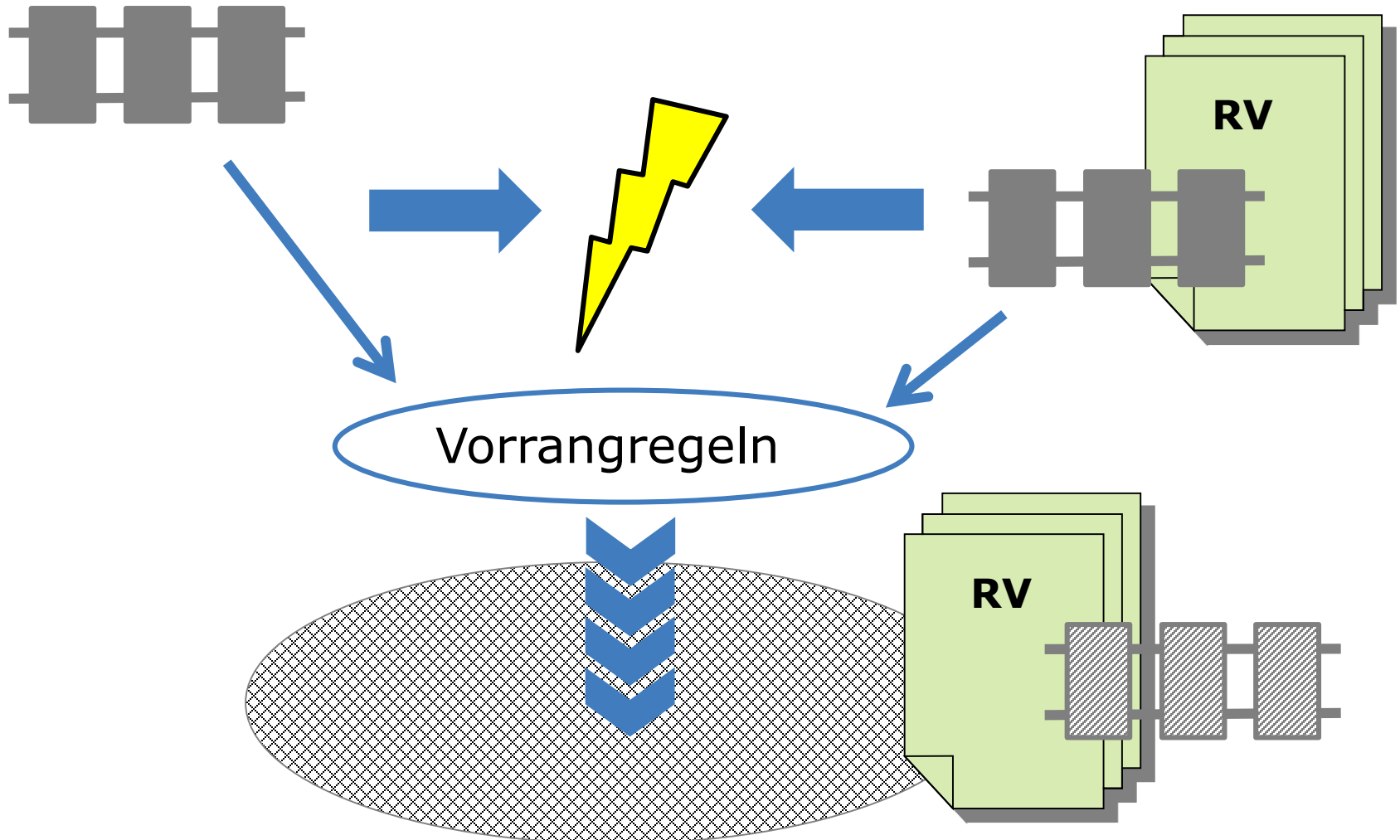

alt

§ 13 Abs. 3 EIBV:

Im Rahmenvertrag sind Regelungen über dessen Änderung oder Kündigung vorzusehen. Es können für diese Fälle auch Vertragsstrafen vereinbart werden.

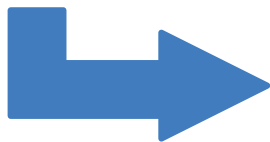

SNB: Pauschale von 400 Euro

neu

BdS

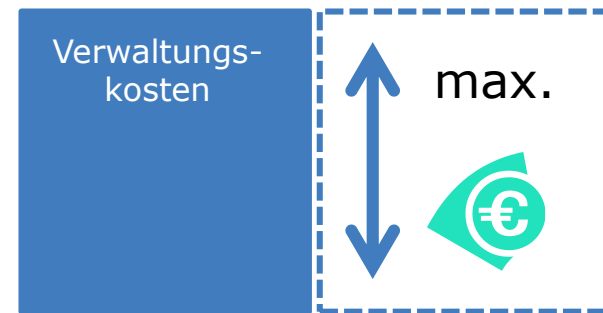
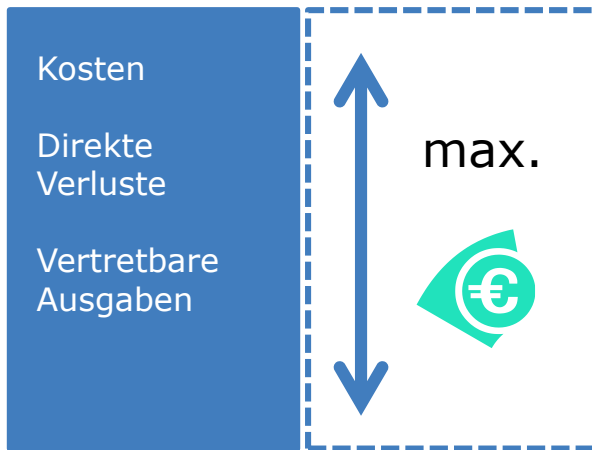
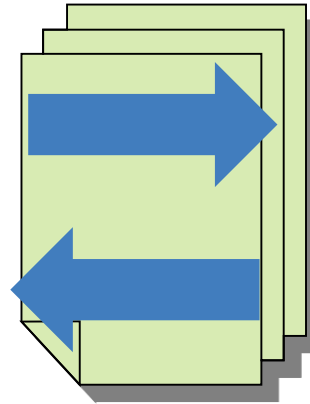

7. „Use it or lose it“ - Regelungen (1)

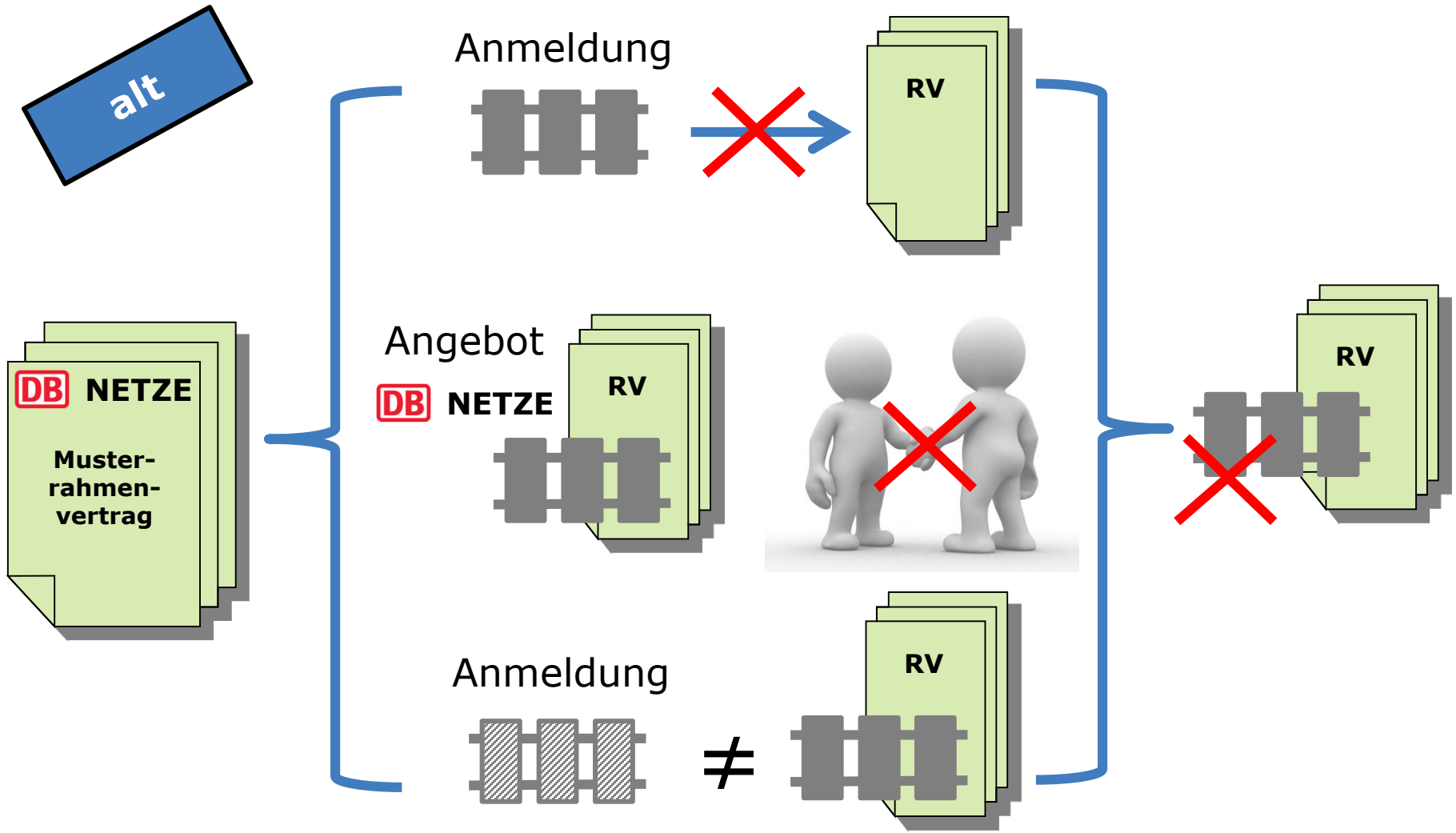

neu

Anmeldung

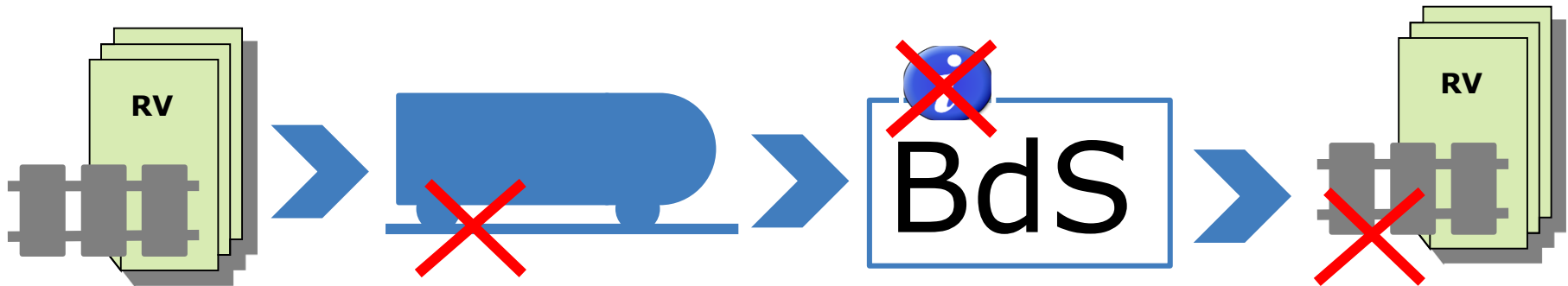
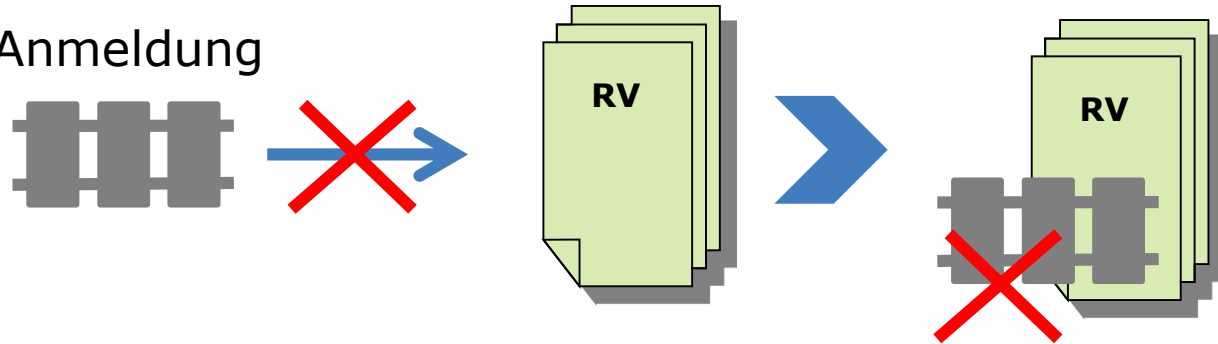

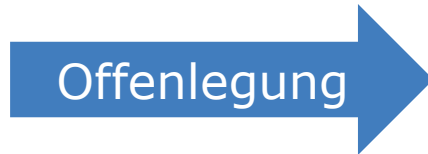
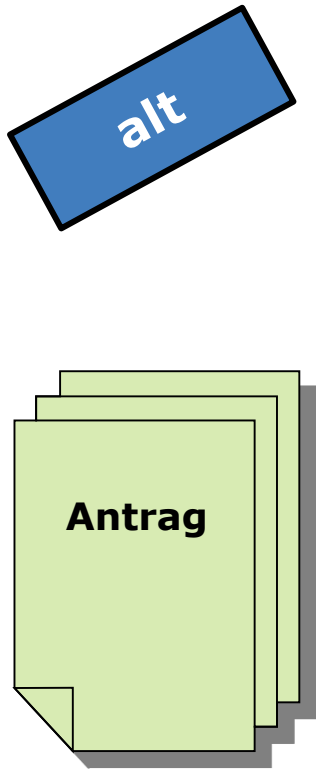

Betriebs- und 
Geschäftsgeheimnisse

Wesentliche Merkmale			
Relation	Zeitlagen	Laufzeit	Beendigungszeitpunkt

neu

Rahmenvertragskapazitätserklärung (pro Streckenabschnitt)



Zugewiesene Rahmenvertragskapazität
und Anzahl der Zugtrassen



Verfügbare Rahmenvertragskapazität
(Richtwerte)

8. Offenlegung (3)



neu

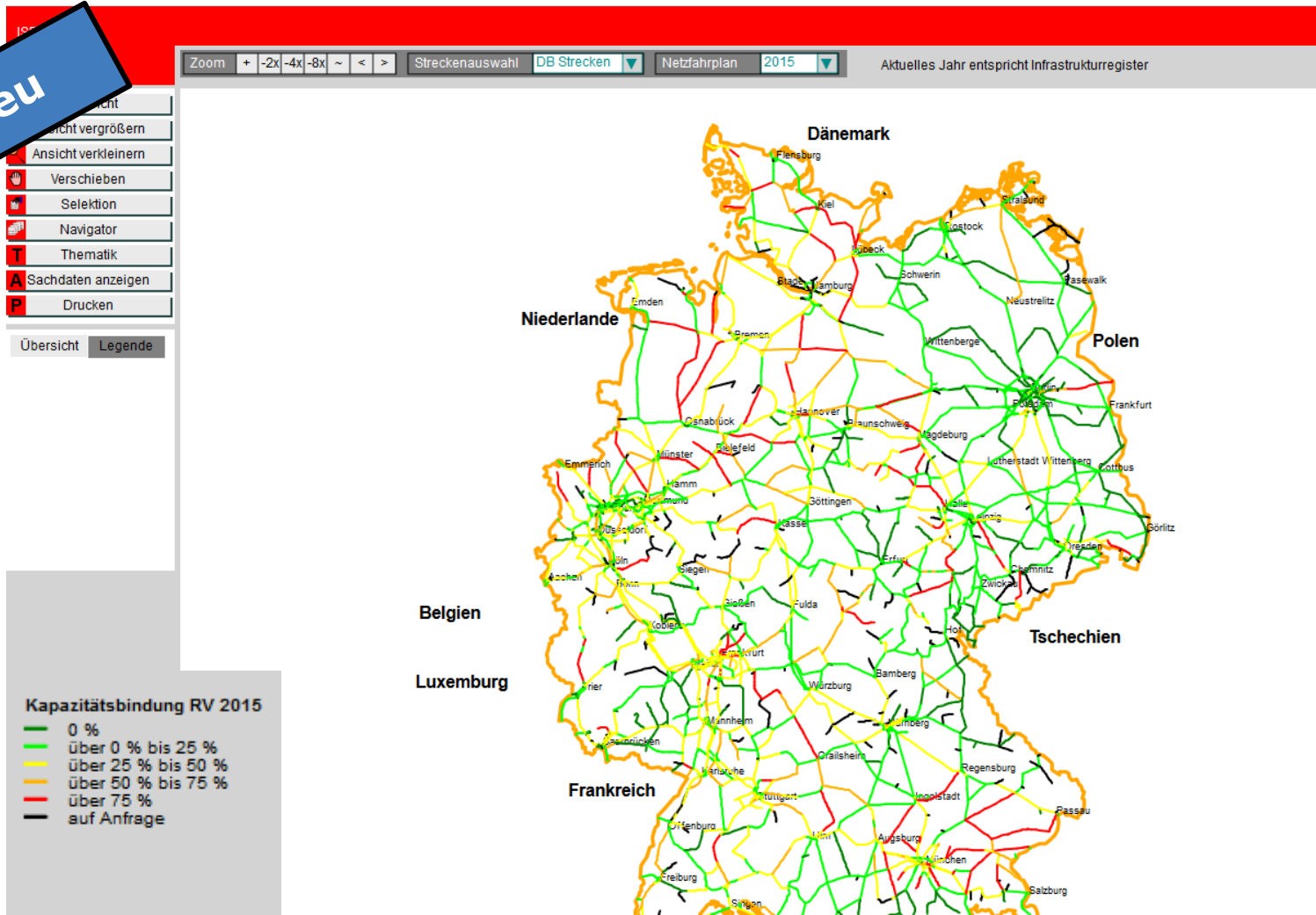

Quelle: Infrastrukturregister DB Netze / Stredax ISR-Viewer



- **Rückwirkung:** Regelungen der Durchführungsverordnung (EU) 545/2016 finden grundsätzlich **Anwendung** auf Rahmenverträge, die **nach dem 15.03.2003 geschlossen wurden**.

III. Fazit und Ausblick



Vielen Dank für Ihre Aufmerksamkeit!

Dr. Johannes Arnade
Referent

+49 228 14-7014
Johannes.Arnade@bnetza.de